

Wireless Voltage Detection - 200 VDC

General Description

ioX Wireless Voltage Detection Sensors measures the voltage between two electrical points. It can be connected to the power and ground of any voltage source and measure within stated accuracy up to 200 VDC. Perfect for measuring battery voltage at specified intervals where sensor data will be wirelessly sent to ioX-Connect, the online sensor monitoring system.

- Wireless interface for detecting voltage
- Detects voltage up to 200 VDC.

Principle of Operation

By connecting the leads on the ioX Wireless Voltage Detection sensor to the positive and ground terminals of a battery, users can measure battery voltage through the ioX Online Sensor Monitoring and Notification System. Notifications can be set up through the online system to alert the user when battery levels reach a certain point. The data is also stored in the online system and can be reviewed and exported as a data sheet or graph.

Example Applications

- Car battery monitoring
- Boat and marine battery monitoring
- RV battery monitoring
- ATV/motorcycle battery monitoring
- Lawn mower and utility vehicle battery monitoring

Features of ioX Wireless Sensors

- Wireless range of 1,200+ feet through 12+ walls *
- Frequency-Hopping Spread Spectrum (FHSS)
- Improved interference immunity
- Improved power management for longer battery life **
- Encrypt-RF® Security (Diffie-Hellman Key Exchange + AES-128 CBC for sensor data messages)
- All ioX sensors now have up to 3200 readings:
 - 10-minute heartbeats = 22 days
 - 2-hour heartbeats = 266 days
- Over-the-air updates (future proof)
- ioX-Monitoring module for wireless sensor monitoring and notification allows users to configure sensors, view data and set alerts via SMS text and email



*Actual range may vary depending on environment.

**Battery life is determined by sensor reporting frequency and other variables. Other power options are also available.

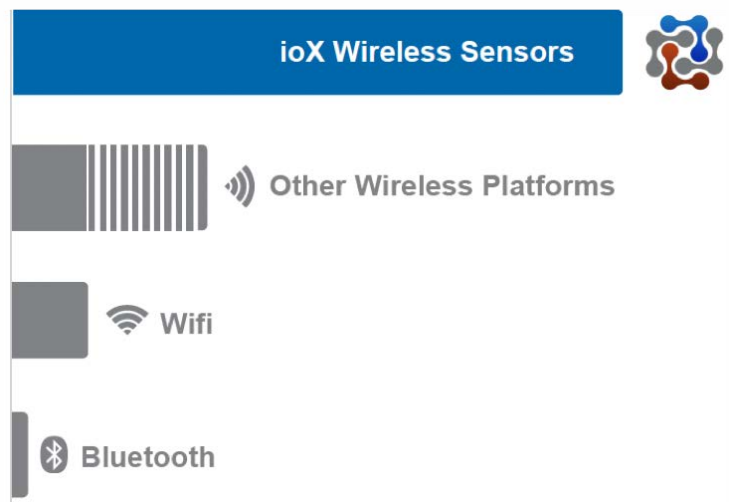
Wireless Range Comparison

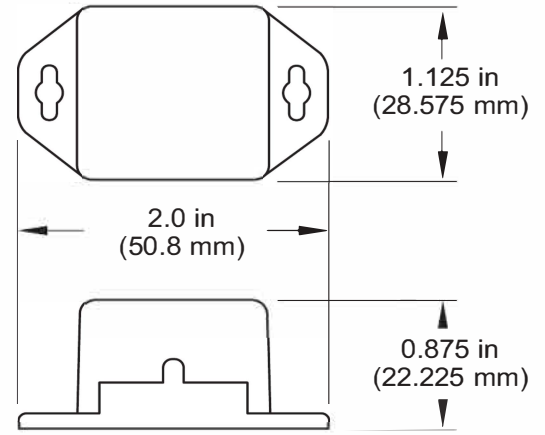
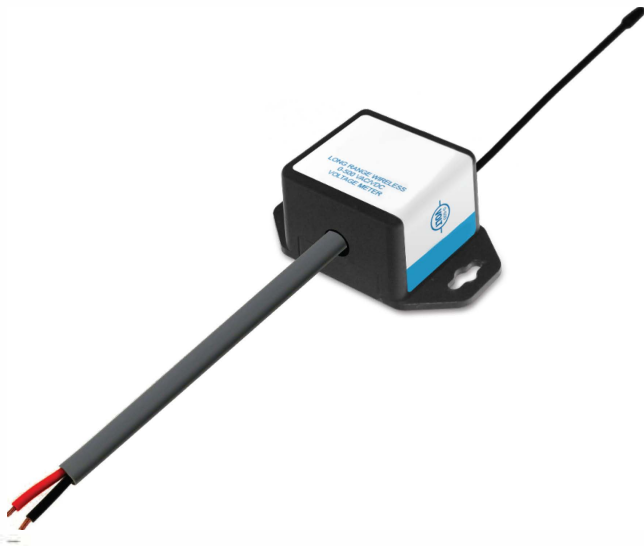



ioX Commercial Coin Cell Wireless 0-200 VDC Voltage Sensor Technical Specifications	
Supply voltage	2.0–3.8 VDC *
Current consumption	0.2 μ A (sleep mode), 0.7 μ A (RTC sleep), 570 μ A (MCU idle), 2.5 mA (MCU active), 5.5 mA (radio RX mode), 22.6 mA (radio TX mode)
Operating temperature range (board circuitry and coin cell)	-7°C to +60°C (20°F to +140°F) **
Optimal battery temperature range (Coin Cell)	+10°C to +50°C (+50°F to +122°F)
Accurate Range	0–200 VDC ***
Absolute maximum voltage	250 VDC ***
Absolute minimum voltage	-250 VDC
Sensor resolution	0.01 VDC
Accuracy	+/- (.15 V + 1% of Reading)
Input Impedance	665 MOhm
Integrated memory	Up to 3200 sensor messages
Wireless range	1,200+ ft non-line-of-sight
Security	Encrypt-RF® (256-bit key exchange and AES-128 CTR)
Weight	0.7 ounces
Certifications	  900 MHz product; FCC ID: ZTL-G2SC1 and IC: 9794A-G2SC1. 868 and 433 MHz product tested and found to comply with: EN 300 220-2 V3.1.1 (2017-02), EN 300 220-2 V3.1.1 (2017-02) and EN 60950

* Circuit cannot withstand negative voltage. Please take care when installing batteries.

** At temperatures above 100°C, it is possible for the board circuitry to lose programmed memory.

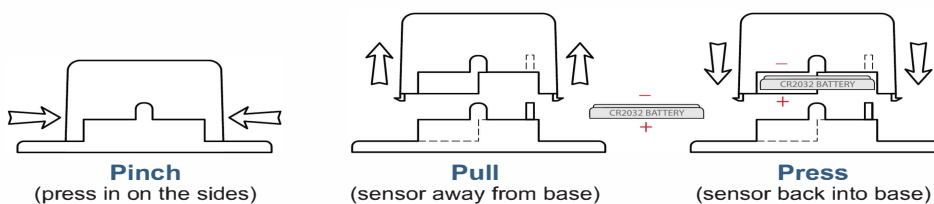

*** The sensor is capable of measuring above 200 volts but may not meet the specified accuracy above this value.

PinchPower™ Enclosures

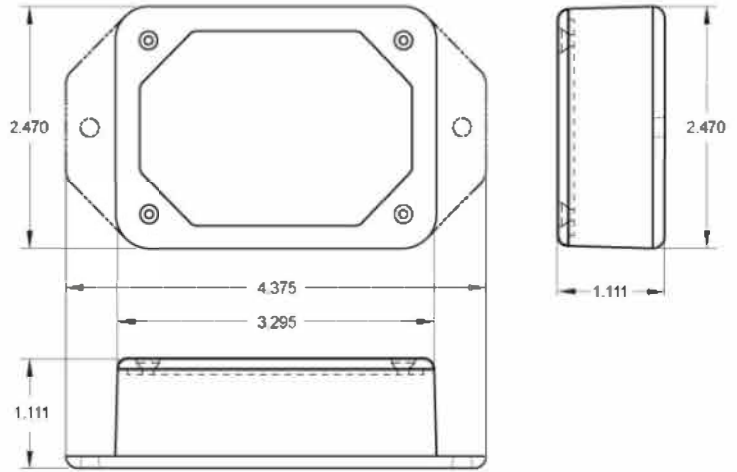



ioX Commercial AA Wireless 0-200 VDC Voltage Sensor | Technical Specifications

Supply voltage	2.0–3.8 VDC (3.0–3.8 VDC using power supply) *
Current consumption	0.2 μ A (sleep mode), 0.7 μ A (RTC sleep), 570 μ A (MCU idle), 2.5 mA (MCU active), 5.5 mA (radio RX mode), 22.6 mA (radio TX mode)
Operating temperature range (board circuitry and batteries)	-18°C to 55°C (0°F to 130°F) using alkaline -40°C to 85°C (-40°F to 185°F) using lithium **
Optimal battery temperature range (AA)	+10°C to +50°C (+50°F to +122°F)
Accurate Range	0–200 VDC ***
Absolute maximum voltage	250 VDC ***
Absolute minimum voltage	-250 VDC
Sensor resolution	0.01 VDC
Accuracy	+/- (.15 V + 1% of Reading)
Input Impedance	665 MOhm
Integrated memory	Up to 3200 sensor messages
Wireless range	1,200+ ft non-line-of-sight
Security	Encrypt-RF® (256-bit key exchange and AES-128 CTR)
Weight	3.7 ounces
Certifications	<div style="display: flex; align-items: center; gap: 10px;">   Industry Canada </div> 900 MHz product; FCC ID: ZTL-G2SC1 and IC: 9794A-G2SC1. 868 and 433 MHz product tested and found to comply with: EN 300 220-2 V3.1.1 (2017-02), EN 300 220-2 V3.1.1 (2017-02) and EN 60950

* Circuit cannot withstand negative voltage. Please take care when installing batteries.

** At temperatures above 100°C, it is possible for the board circuitry to lose programmed memory.



*** The sensor is capable of measuring above 200 volts but may not meet the specified accuracy above this value.

Power Options

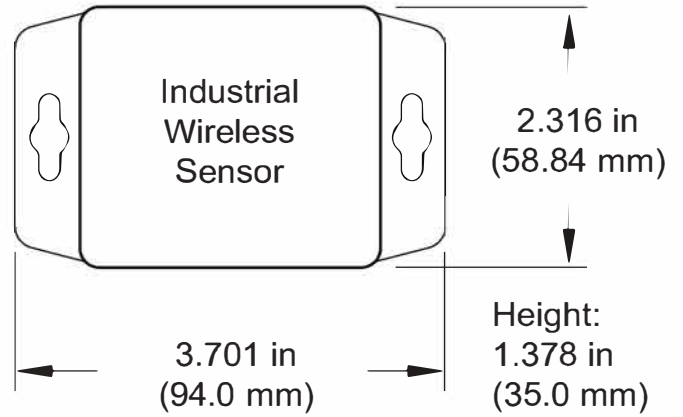
The standard version of this sensor is powered by two replaceable 1.5 V AA sized batteries (included with purchase). This sensor is also available with a line power option. The line powered version of this sensor has a barrel power connector allowing it to be powered by a standard 3.0–3.6 V power supply. The line powered version also uses two standard 1.5 V AA batteries as backup for uninterrupted operation in the event of line power outage. Power options must be selected at time of purchase, as the internal hardware of the sensor must be changed to support the selected power requirements.



ioX Industrial Wireless 0-200 VDC Voltage Sensor | Technical Specifications

Supply voltage	2.0–3.8 VDC (3.0–3.8 VDC using power supply) *	
Current consumption	0.2 μ A (sleep mode), 0.7 μ A (RTC sleep), 570 μ A (MCU idle), 2.5 mA (MCU active), 5.5 mA (radio RX mode), 22.6 mA (radio TX mode)	
Operating temperature range (board circuitry and battery)	-40°C to +85°C (-40°F to +185°F) **	
Included battery	Max temperature range	-40° to +85°C (-40° to +185°F)
	Capacity	1500 mAh
Optional solar feature	Solar panel	5VDC/30mA (53mm x 30mm)
	Charging temperature range	0° to 45°C (32° to 113°F)
	Max temperature range	-20° to 60°C (-4° to 140°F)
	Included rechargeable battery	600 mAh/>2000 charge cycles (80% of initial capacity)
	Solar efficiency	Optimized for high and low-light operation ***
Accurate Range	0–200 VDC ***	
Absolute maximum voltage	250 VDC ***	
Absolute minimum voltage	-250 VDC	
Sensor resolution	0.01 VDC	
Accuracy	+/- (.15 V + 1% of Reading)	
Input Impedance	665 MOhm	
Integrated memory	Up to 3200 sensor messages	
Wireless range	1,200+ ft non-line-of-sight	
Security	Encrypt-RF® (256-bit key exchange and AES-128 CTR)	
Weight	4.7 ounces	
Enclosure rating	NEMA 1, 2, 4, 4x, 12 and 13 rated, sealed and weather proof	
UL rating	UL Listed to UL508-4x specifications (File E194432)	
Certifications	 	900 MHz product; FCC ID: ZTL-G2SC1 and IC: 9794A-G2SC1. 868 and 433 MHz product tested and found to comply with: EN 300 220-2 V3.1.1 (2017-02), EN 300 220-2 V3.1.1 (2017-02) and EN 60950

* Circuit cannot withstand negative voltage. Please take care when installing batteries.

** At temperatures above 100°C, it is possible for the board circuitry to lose programmed memory.

*** Light present 25% of day yields 125% of operating power to support 10-minute heartbeats.

**** The sensor is capable of measuring above 200 volts but may not meet the specified accuracy above this value.

Proper Installation

If the sensor is not connected to the battery (power source) properly, it will appear that the sensor is broken. Please follow this wiring diagram to ensure proper performance and detection.

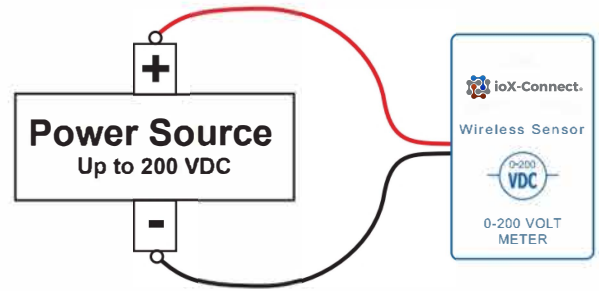

Commercial Grade Sensors

ioX commercial grade sensors are designed for applications in ordinary environments (normal room temperature, humidity and atmospheric pressure). Do not use these sensors under the following conditions as these factors can deteriorate the product characteristics and cause failures and burnout.

- Corrosive gas or deoxidizing gas: chlorine gas, hydrogen sulfide gas, ammonia gas, sulfuric acid gas, nitric oxides gas, etc.
- Volatile or flammable gas
- Dusty conditions
- Low-pressure or high-pressure environments
- Wet or excessively humid locations
- Places with salt water, oils chemical liquids or organic solvents
- Where there are excessively strong vibrations
- Other places where similar hazardous conditions exist

Use these products within the specified temperature range. Higher temperature may cause deterioration of the characteristics or the material quality.

Industrial Grade Sensors | Type 1, 2, 4, 4X, 12 and 13 NEMA Rated Enclosure

ioX Industrial sensors are enclosed in reliable, weatherproof NEMA-rated enclosures. Our NEMA-rated enclosures are constructed for both indoor or outdoor use and protect the sensor circuitry against the ingress of solid foreign objects like dust as well as the damaging effects of water (rain, sleet, snow, splashing water, and hose-directed water).

- Safe from falling dirt
- Protects against wind-blown dust
- Protects against rain, sleet, snow, splashing water, and hose-directed water
- Increased level of corrosion resistance
- Will remain undamaged by ice formation on the enclosure

For more information about our products or to place an order, please contact our sales department at sales@iox-connect.com

Visit us on the web at www.iox-connect.com