



Wireless PAR Light Meter

General Description

The ioX PAR (Photosynthetically Active Radiation) Light Meter monitors the ideal light wavelength plants need for photosynthesis. Commercial growers, greenhouse staff, and grow house managers can use these quantum light sensors to monitor light presence or absence, measure light intensity, and record daily saturation levels that affect plant health and growth.

Features

- Light sensor rated to IP-68 and built with a self-cleaning, anodized aluminum body with acrylic diffuser
- Blue-enhanced silicon photodiode with a spectral range of 389-692 nm +/- 5 nm
- 5 m of shielded, twisted-pair wire with TPR jacket (high water resistance, high UV stability, and flexible in cold conditions)
- Sensor sold with mounting bracket and leveling plate

Principle of Operation

The ioX PAR Light Meter uses a blue-enhanced silicon photodiode with a spectral range of 389-692 nm +/- 5 nm to measure the specific wavelengths of light that plants need for photosynthesis. The PAR Light Meter measures Photosynthetic Photon Flux Density (PPFD) in $\mu\text{mol}/\text{m}^2/\text{s}$. PPFD is the amount of PAR light (photons) that arrive at the plant's surface each second. The PPFD measurement is integrated throughout the day to produce the Daily Light Integral (DLI) in $\text{mol}/\text{m}^2/\text{day}$. The PAR Light Meter resets the DLI accumulation at a customer configurable time of day. In addition, the sensor reports immediately when configurable light level thresholds and DLI thresholds are breached to keep users informed of the most critical data as quickly as possible.

Features of ioX-Connect Sensors

- Wireless range of 1,200+ feet through 12+ walls ¹
- Frequency-Hopping Spread Spectrum (FHSS)
- Best-in-class interference immunity
- Best-in-class power management for longer battery life ²
- Encrypt-RF® Security (Diffie-Hellman Key Exchange + AES-128 CBC for sensor data messages)
- Datalogs 2000 to 4000 readings if gateway connection is lost (non-volatile flash, persists through the power cycle):
 - 10-minute heartbeats = ~ 22 days
 - 2-hour heartbeats = ~ 266 days
- Over-the-air updates (future proof)
- Free ioX-Basic online wireless sensor monitoring and notification system to configure sensors, view data and set alerts via SMS text and email

¹ Actual range may vary depending on environment.

² Battery life is determined by sensor reporting frequency and other variables. Other power options are also available.

Wireless Range Comparison

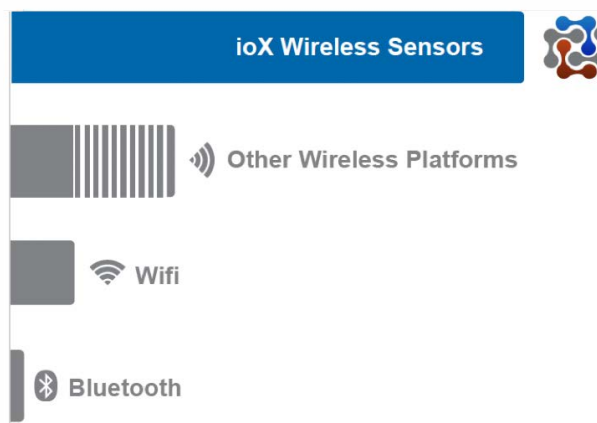

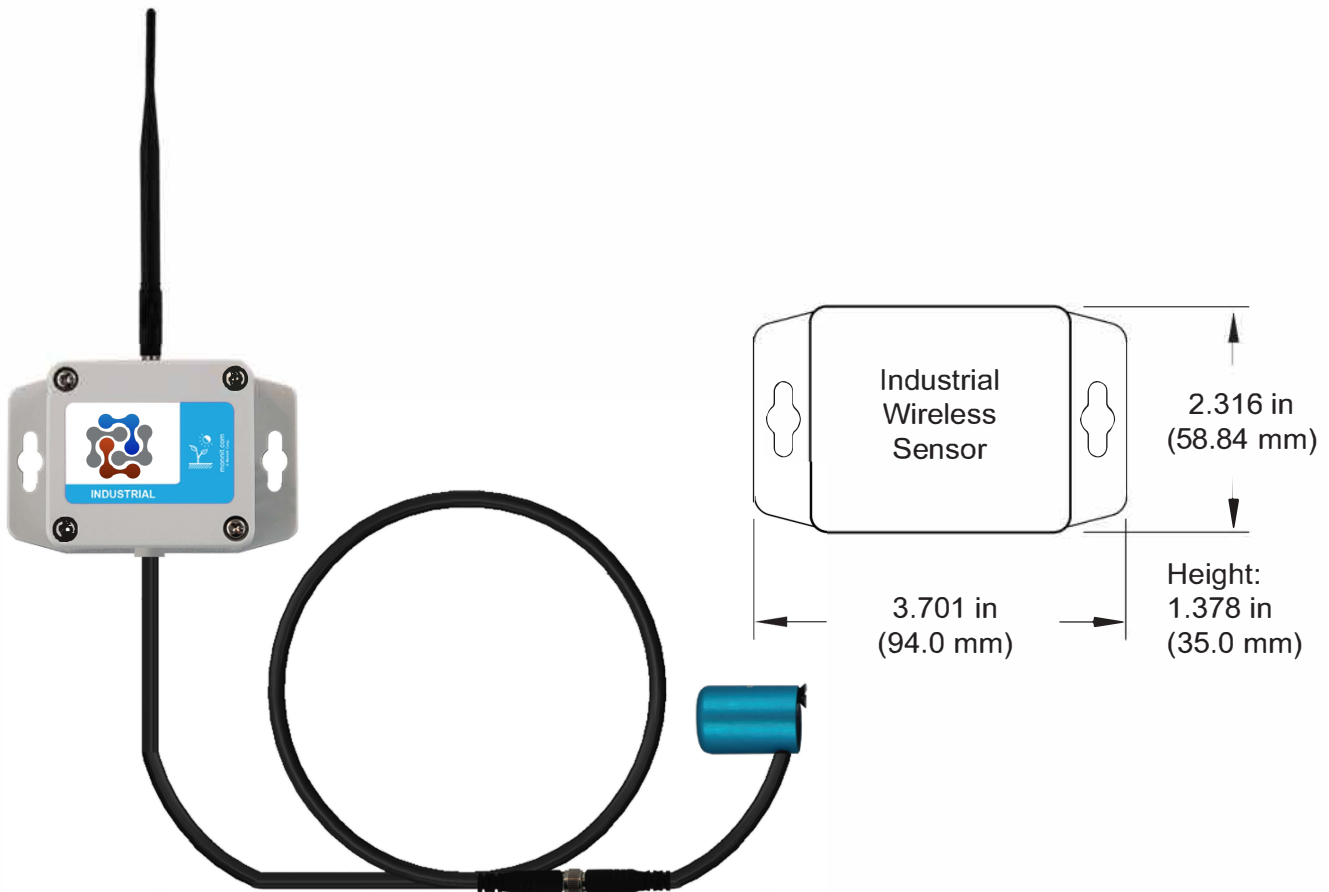

Example Applications

- Grow houses
- Greenhouses
- Growth chambers
- Outdoor growing environments
- Aquaculture
- Aquariums



ioX Wireless PAR Light Meter Industrial Platform | Technical Specifications

Part Number		MNS2-x-IN-LS-PAR (x: 9=900 MHz, 8=868 MHz, 4=433 MHz)
Supply voltage		2.0–3.8 VDC (3.0–3.8 VDC using power supply)
Current consumption		0.2 μ A (sleep mode), 0.7 μ A (RTC sleep), 570 μ A (MCU idle), 2.5 mA (MCU active), 5.5 mA (radio RX mode), 22.6 mA (radio TX mode)
Operating temperature range		-40°C to +70°C (-40°F to +158°F)
Included battery	Max temperature range	-40°C to +70°C (-40°F to +158°F)
	Capacity	1500 mAh
Datalogging		Datalogs 2000 to 4000 readings if gateway connection is lost (non-volatile flash, persists through the power cycle): - 10-minute heartbeats = ~ 22 days - 2-hour heartbeats = ~ 266 days
Wireless range		1,200+ ft non-line-of-sight
Security		Encrypt-RF® (256-bit key exchange and AES-128 CTR)
Weight		9.4 ounces (266 g)
Enclosure rating		NEMA 1, 2, 4, 4x, 12 and 13 rated, sealed and weather
UL rating		UL Listed to UL508-4x specifications (File E194432)
Certifications	   Industry Canada	900 MHz product; FCC ID: ZTL-G2SC1 and IC: 9794A-G2SC1. 868 and 433 MHz product tested and found to comply with: EN 300 220-2 V3.1.1 (2017-02), EN 300 220-2 V3.1.1 (2017-02) and EN 60950

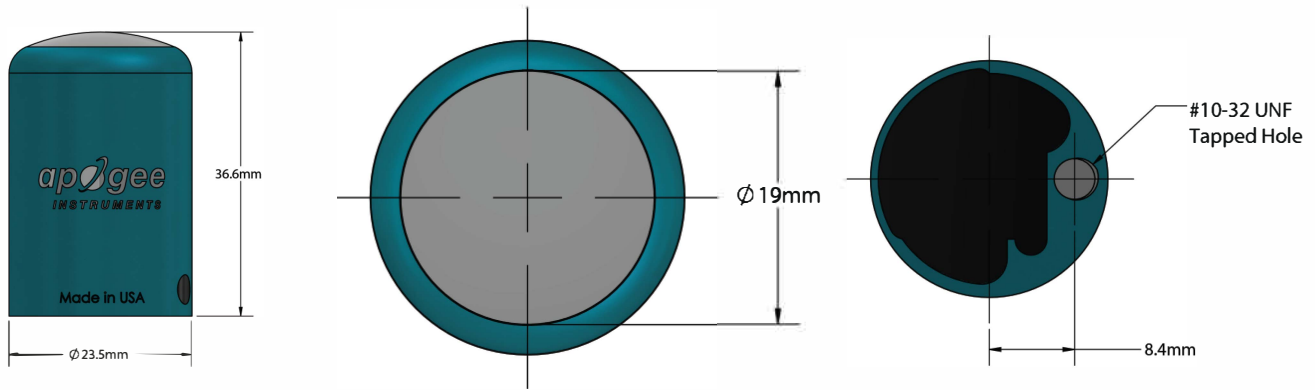

Element Specifications

PAR (Full-Spectrum Quantum) Element

Element Type	SQ-500-SS from Apogee Instruments ©
Range	0.0 to 4000.0 $\mu\text{mol}/\text{m}^2/\text{s}$
Resolution	0.1 $\mu\text{mol}/\text{m}^2/\text{s}$
Dimensions	Diameter: 0.944 in. (24 mm)
	Height: 1.457 in. (37 mm)
Response Time	Less than 1 ms ¹
Repeatability	0.5 %
Overall Accuracy	+/- 6 % ²
Long-term Drift	Less than 2% per year
Field of View	180°
Spectral Range	389 to 692 nm +/- 5 nm
Azimuth and Tilt Error	Less than 0.5% each
Temperature Response	-0.11 +/- 0.04 % per C ³
Operating Environment	-40° to 70° C; 0 to 100 % relative humidity; can be submerged in water up to depths of 30 m (Cable and Sensor Element)
Cable General Composition	5 m of shielded, twisted-pair wire with TPR jacket (high water resistance, high UV stability, flexibility in cold conditions)
Connector	IP68 marine-grade stainless-steel keyed M8 6-pin connector ⁴

- Response time is less than 1 ms on the SQ-500-SS itself, but the response time is also limited by the configurable measurement interval on the sensor, which is as low as one second and is one minute by default.
- Accuracy is a combination of raw element accuracy, non-linearity, and voltage measurement accuracy by the ioX-Connect sensor base. The sensor must be level to achieve this accuracy level.
- The temperature response is adjusted out when the temperature compensation configuration is turned on in ioX-Connect Platform.
- The cable is only waterproof when connector ends are fully seated, and connector nut is completely hand tightened to engage o-ring seal in the connector.

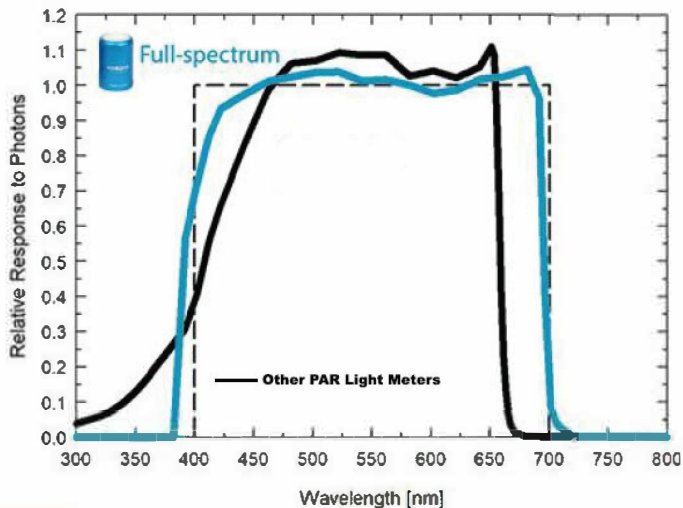

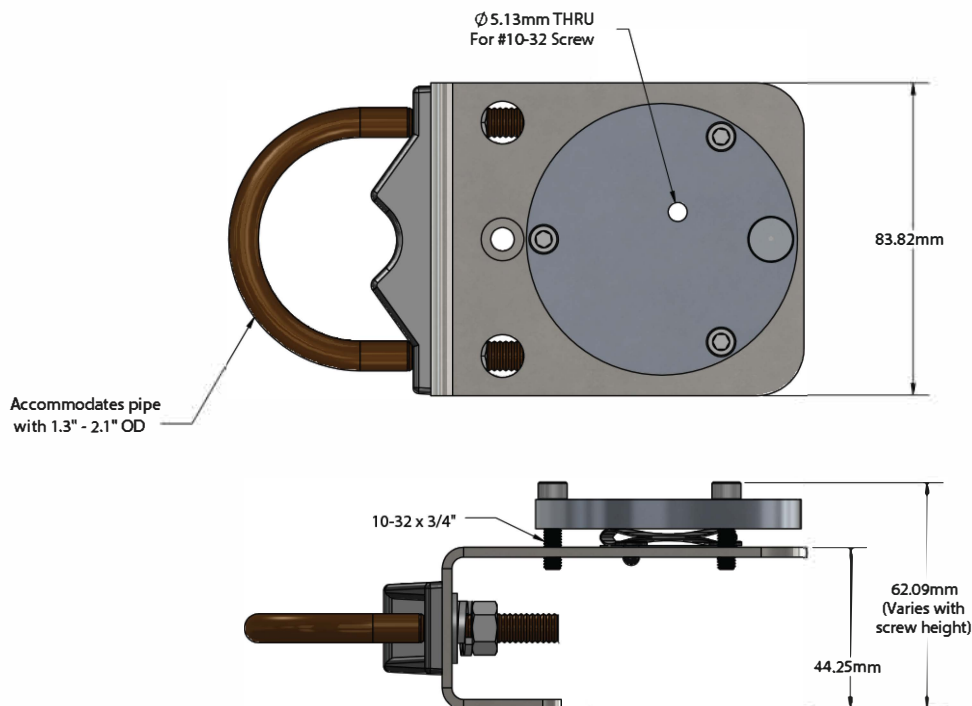

Mounting Bracket	
Weight	14.8 ounces (420 g)
Features	Integrated bubble-level #10-32 threaded hole for mounting sensor

Sensor Data	
User Interface: PPFd: xxxx.x umol/m2/s Light State: No Light, Light, Saturated DLI: xxxxxxx.xxx mol/m2/day	Raw Data: (data type, conversion, units) ³ PPFd: unsigned int, raw / 10, µmol/m2/s Light State: unsigned char, 0 = No Light, 1 = Light, 2 = Saturated Temperature: signed int, raw / 10 (no UI), Celsius ^{1,2} Raw Voltage: signed long, no conversion needed (no UI), µVolts ¹ DLI: unsigned long, raw / 1000, mol/m2/day
PPFD Accuracy, Range, Resolution, Response Time	+/- 6 %, 0.0 to 4000.0 µmol/m2/day, 0.1 µmol/m2/day, Less than 1 ms
DLI PAR Accuracy, Range, Resolution	+/- 6 %, 0.000 to 10000.000 mol/m2/day, 0.001 mol/m2/day ^{4,5}
Light State	Produces No Light, Light, or Saturated readings based on customer configurable light levels.
Temperature Accuracy, Range, Resolution, Response Time	+/- 1°C, -40.0°C to 125.0°C, 0.1°C, 5+ minutes ⁶
Raw Voltage	Voltage directly from PAR sensor element in µVolts, not meant for direct use

1. Data is not shown in the UI.
2. The temperature element is housed inside a sealed sensor base, so it may not read the same temperature the sensor element is exposed to, or the temperature response time may be very long. Keep this in mind when using the temperature compensation configuration on the sensor.
3. Raw data refers to data as it comes directly from the ioX sensor itself, not how it is represented in raw data exports from ioX-Connect Sensor Platform. Raw data in ioX-Connect is already converted as indicated by "conversion."
4. DLI range is numerically capable of exceeding 10000.0 mol/m2/day but is limited by the max PPFd readings, so only ~345.6 mol/m2/day is possible under normal conditions. DLI = PPFd * seconds in a day (86400).
5. DLI accuracy generally follows the accuracy of the PAR element. DLI accuracy will also vary based on measurement interval. The PAR Light Meter measures at a single instant in time and assumes that the value was present during the entire measurement interval. Closer to true DLI will be approached, the lower the measurement interval is set. Even with this approach, the DLI estimation can still be very close to true DLI.
6. Temperature response time is very long because the temperature element is stored in a sealed sensor base, not the sensor element.

Industrial Grade Sensors | Type 1, 2, 4, 4X, 12 and 13 NEMA Rated Enclosure

ioX industrial sensors are enclosed in reliable, weatherproof NEMA-rated enclosures. Our NEMA-rated enclosures are constructed for both indoor or outdoor use and protect the sensor circuitry against the ingress of solid foreign objects like dust as well as the damaging effects of water.

- Safe from falling dirt
- Protects against wind-blown dust
- Protects against rain, sleet, snow, splashing water, and hose-directed water
- Increased level of corrosion resistance
- Will remain undamaged by ice formation on the enclosure



ioX-Connect is an EAMS
Technologies Inc brand.
Orlando, FL 32746
sales@iox-connect.com

For more information about our products or to place an order, please contact our sales department at sales@iox-connect.com

Visit us on the web at www.iox-connect.com